

Two Systems for Perfect Invisible Joints

LUMINA



PRODUCTIVITY AND PRECISION





Perfect panel processing is our passion

Our engineers are among the world's best. Their visionary imagination and exceptional skill guarantee that our machines are the highest performance, most flexible and safest in the world today. Customers appreciate our capability to develop and produce excellent products quickly at equitable prices and high quality. Integrative, networked solutions are decisive for machining wood and panels worldwide.

This is why HOLZ-HER offers a range of products matched to one another and always develops a complete product series, from

an entry-level machine right up through all performance ranges to the comprehensive top model. All service activities and product training courses are planned alongside new products. This ensures that, in addition to being offered a new machine, customers can also take advantage of a complete range of services. This focuses on practical solutions and greater customer benefit.

Absolute precision in
production guarantees
perfect results for customers.



What you can expect from us

- We want to understand our customers and partners as well as we possibly can and we want to optimize and increase their success by providing them with innovative products and services.
- Close contact with our dealers as well as with end customers, cabinet makers, interior architects and industrial workshops is one of HOLZ-HER's particular strengths.
- HOLZ-HER places a great deal of value on providing above-average performance in all areas, looking ahead to the future, achieving continuity and consistency in development and design and perfecting production, as well as providing in-depth sales and service advice.
- The ability to recognize and anticipate trends is a key skill for strong companies like HOLZ-HER. This requires the qualifications of each and every employee to be kept up to date. For this reason, HOLZ-HER places a great deal of emphasis on professional training for young employees. A choice selection of advanced occupational courses and personal training keep the learning process going.



The WEINIG Group: Machines and systems for solid wood and panel processing

Innovative state-of-the-art technology, comprehensive services and system solutions through to turnkey production lines: the WEINIG Group is your partner for profitable processing of solid wood and panels. WEINIG quality and profitability give small businesses and industrial operations a decisive edge in the global competition.



LUMINA series

In addition to our LTRONIC and Glu Jet systems, our LUMINA series offers everything required for a professional edgebander. Up to 18 NC servo-axes for maximum automation of all machining units with exact repetition at the touch of a button. Even the pressure and glue quantity settings can be made fully automatically and adapted to the specific requirement. The HOLZ-HER LUMINA with LTRONIC laser edging unit sets the highest, professional standards for edgebanding without compromises.



Illustrations may contain optional features.



- Fully automatic control of machining units at the touch of a button using NC servo-axes without opening the hood.
- Ergonomic operation with 18.5" latest generation touch screen control in 16:9 format. Includes an intelligent edging library for rapid selection of laser edges.
- Maximum precision and processing reliability for many years with torsionally stiff, welding machine columns.



Intelligent energy management for HOLZ-HER edgebanders.



For short intervals between workpieces and optimized edge protrusions.

HOLZ-HER ensures perfectly invisible joints

The LUMINA series offers a unique combination for panel processing:
Two systems for perfect invisible joints.

- Our Glu Jet application system for standard use of PUR glue.
- LTRONIC, the laser edging unit from HOLZ-HER is unbeatable in terms of speed and cost efficiency.

Glu Jet – waterproof invisible joints with thin film technology

Industrial technology for small shops – with the HOLZ-HER Glu Jet system, you can process PUR glue on a standard basis; just as simply as EVA glue. Strong arguments for you and your customers:

- No glue pots.
- No expensive nitrogen tanks.
- High strength joint for extremely long service life.
- Resistant to heat and water, providing quality advantages in all areas of cabinetmaking.



Heat-up time
3 minutes



Glue change*
3 minutes

* to PUR glue, to EVA glue and color change



Cleaning
3 minutes



LTRONIC and GLU JET –
for superior edge appearance.
Unbeatable as twin pack! <



LTRONIC LASER EDGE BANDER

LTRONIC – perfect invisible joints with laser edging

Co-extruded and subsequently coated laser edging can be processed with LTRONIC. The NIR module in our LTRONIC unit can transfer heat energy quickly and precisely to the specific point required making it ideal for activation of function layers on laser edging.

- Visually perfect results – tone in tone with invisible joints.
- No heat-up time.
- Noiseless processing.
- No cleaning work.
- Pioneer in terms of energy efficiency.
- Completely clean postprocessing.



Heat-up time
None



Glue change
None



Cleaning
None



Perfect results at
the touch of a button
with LTRONIC.



NIR-MODUL

Your advantages with the NIR module in the *LTRONIC*

■ Immediate availability

No non-productive heat-up times whatsoever. Immediate availability at the touch of a button.

■ Noiseless processing

LTRONIC operates without any noise emissions whatsoever and without compressed air.

■ High tech cooling from CNC technology

The NIR module (Near Infrared Radiation) is kept at a uniform temperature by its liquid cooling system allowing continuous production without pauses for cooling.

■ High energy efficiency

The wave length of our NIR module is very close to the intensity of the diode laser allowing it to optimize its energy with the utmost precision over the entire length of the workpiece. No energy is lost during set-up times.



Glu Jet and LTRONIC changing station

On the LUMINA users can change over from the LTRONIC to the Glu Jet unit as required within minutes using the high precision HSK interface from our CNC technology.

The LUMINA has an automatic unit recognition feature and is ready for use immediately after changing over to the Ltronic. The change over time from edge to edge is only 5 minutes.

On the LUMINA the Glu Jet as well as the LTRONIC both have edging magazines with optimized feed angles, allowing uncompromising edging variety, stating from modern high gloss edging to thick edging cross sections in the solid wood range.

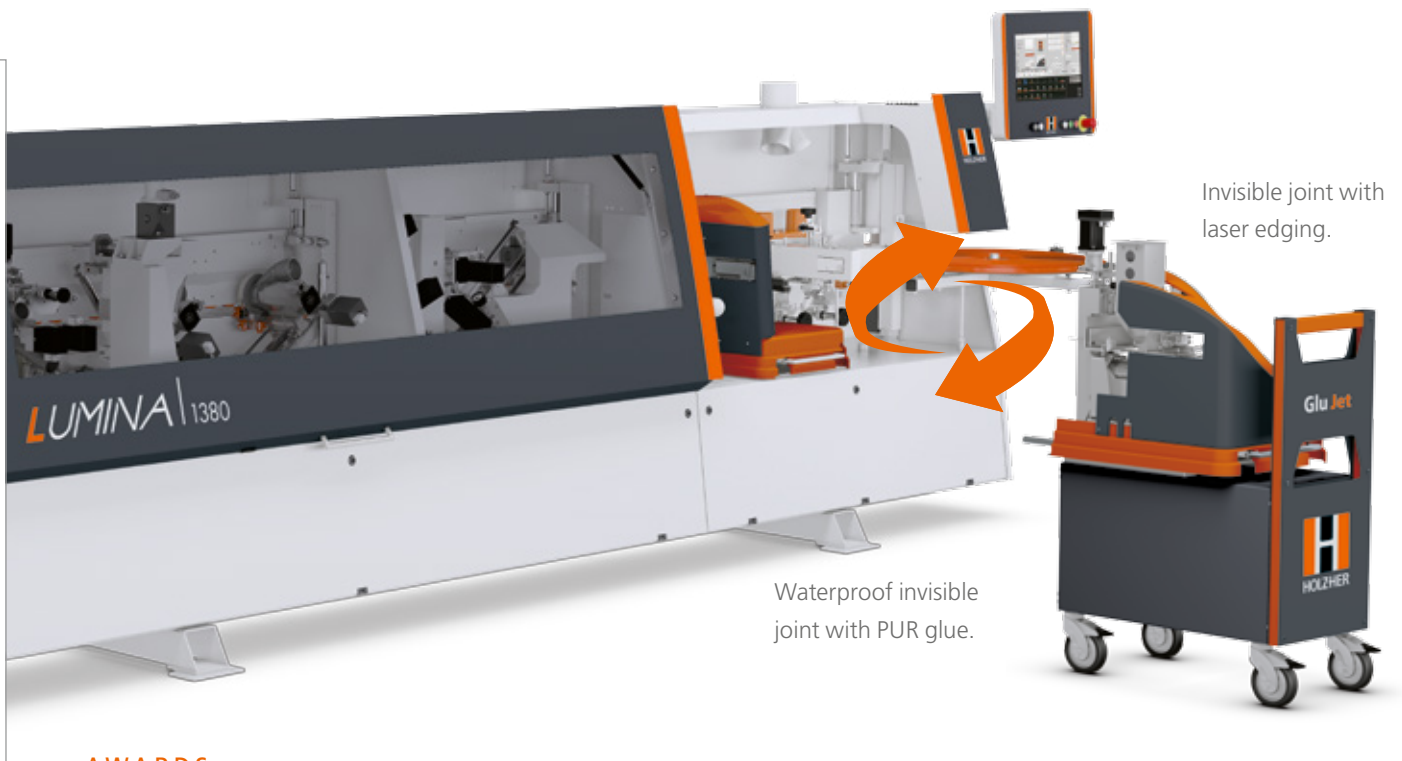

AWARDS

2012/14



GOLD STAR AWARD
AWISA, Brisbane (Australia)

2014



TROPHÉE EXPOBOIS
EXPOBOIS, Paris (France)

2014/16

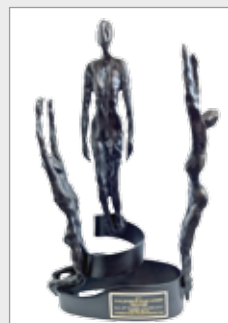

CHALLENGER AWARD
IWF, Atlanta (USA)

2016



GOLD STAR AWARD
AWISA, Melbourne (Australia)

Edge Control Touch

The HOLZ-HER Edge Control Touch provides extremely high performance and is exemplary for its simple operation. Ergonomic, simple and uniform tablet design.

Display

- 18.5"-Touch screen with 16:9 format.
- Brilliant graphic display of machining process.
- Simple operation – rotating and swiveling control panel at eye height.

Operation

- Electronically controlled set-up processes with 100% repetition accuracy.
- Clear and complete acquisition of all operating data: Total running meters, total parts, total hours with reset.
- Custom user management with password protection and single authorization.

Equipment/Service

- Network connectivity.
- Online maintenance, high speed data interchange with HOLZ-HER service department.
- Barcode interface for automatic program call-up.
- External USB port for data backup and system updates.
- Connection to HOLZ-HER process data acquisition system for direct read-out of operating data (optional).



Edge Control Touch –
high standards guarantee your
investment for the future.



Laser edging at the touch of a button.

Edging database

A highlight is the edging library completely integrated into the control. All of the very latest co-extruded and subsequently coated edging are already stored here as a factory-provided item and can be simply selected by the user via the standard touch screen.

Each laser edging needs a specific energy entry, which, by way of an example, depends on the edge thickness or the color. After selection LTRONIC adjusts the respective energy requirement automatically. And if your edge is not listed in the library the edge calculator takes care of the required energy calculation for you.



Rotating and pivoting control panel.



LUMINA 1375

Our LUMINA 1375 offers a unique combination for processing panels. The change-over units LTRONIC and Glu Jet, provide two methods for obtaining perfect, invisible joints. Glu Jet with waterproof PUR glue or LTRONIC for laser edging. The LUMINA technology allows you to change over from the LTRONIC to the Glu Jet unit in some few minutes, to meet your momentary requirements. 12 NC servo-axes ensure rapid and reproducible setup operations. The LUMINA 1375 offers the perfect starter solution for small craft shops.



LUMINA 1380

The LUMINA 1380 also has both change-over units the LTRONIC and Glu Jet, for perfect, invisible joints. Up to 18 NC servo-axes provide maximum automation and productivity. From high tech jointing cutting to complete finishing, this machine offers everything for perfect edgebanding. The all-rounder in this class.

Units for 100 percent repetition accuracy!

All units must satisfy maximum requirements right down to the last detail to obtain the same precision results repeatedly at high processing rates. The shaping cutter unit is an example of what is important.

Because 100 percent repetition accuracy is highly significant for professional edgebanding.

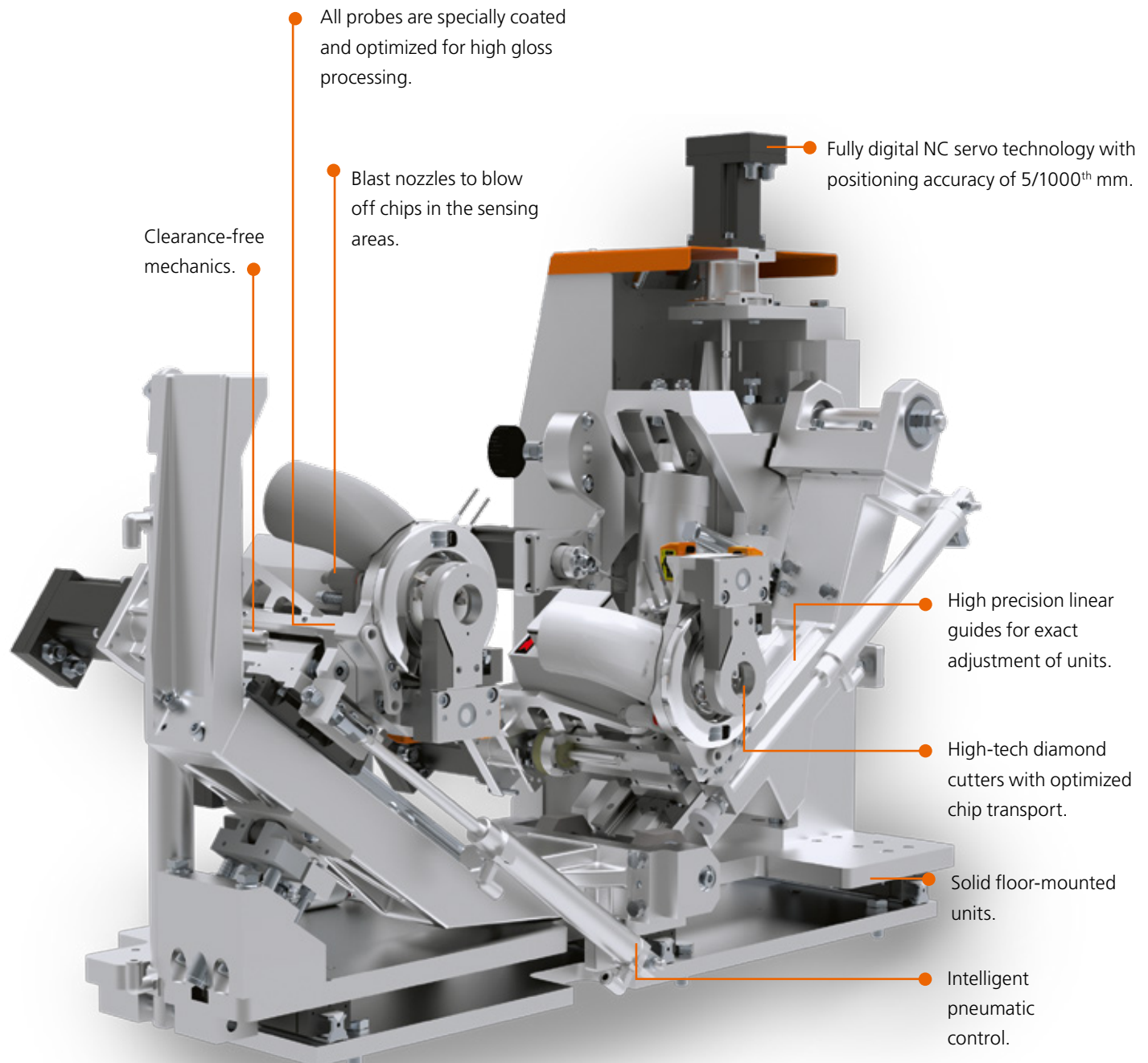



Pre-milling

Cut edgings often have small tears in the top layer. The pre-milling cutter unit ensures perfect glued surfaces and prepares the panels for the gluing process. Equipped with patented air-stream jointing tools.

Including height adjustment for optimum utilization of cutters.

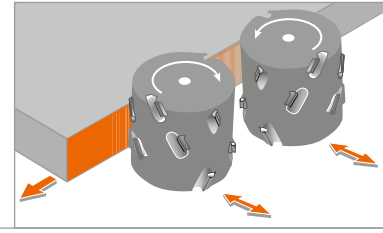

LTRONIC/Glu Jet edging magazine

The special LUMINA edging magazine combines the unique, acute feed angle of only 7 degrees for extreme edging cross sections in the solid wood range with optimum feed angle for activating laser edging.

Synchro drive, automatic edging separation as well as automatic edge monitoring are all standard features.

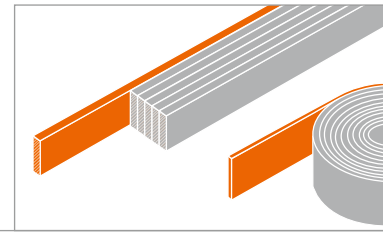

Motor-driven pressure unit

Synchronously driven pressure unit with automatic adaptation to feed rate thanks to NC servo-axes for motor-driven adjustment to correct edge thickness (optional).

Straight and tapered pressure rollers for perfectly glued joints.

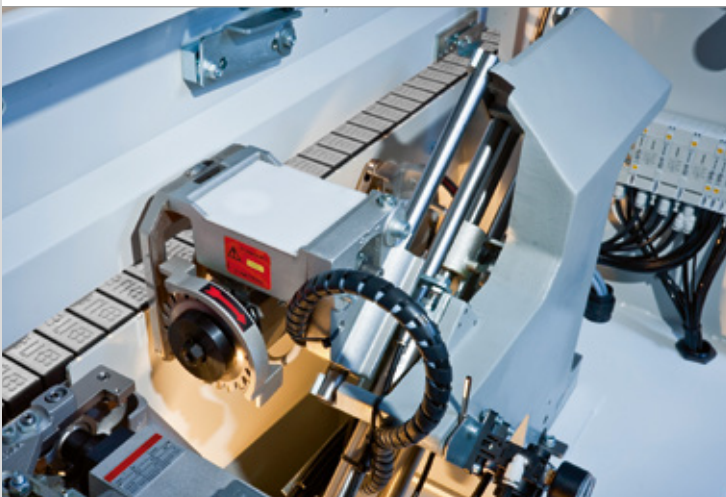
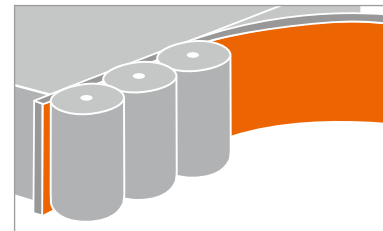

Pneumatic end trimming unit

For straight or chamfered end trimming on thin edging; a standard feature allows this unit to be pivoted to 10 degrees pneumatically. High quality version with stable cast iron pillars.

Sawing motors each with two guides for precisely trimming off protruding edging.

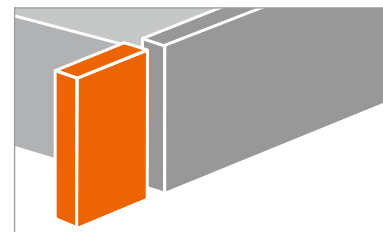



Pneumatic cutter unit

Multifunction cutter unit for flush cut on edging with thickness up to 8 mm, radiuses up to 3 mm, pivots 0–15 degrees. Including diamond tools.

Further equipment:

- Integrated chip collection in tool.
- ProLock system.
- Motorized version (optional).

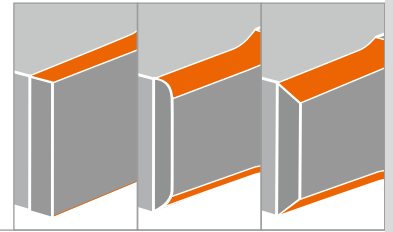

Multi-function cutting unit with 4 NC servo-axes

For flush, radius and bezel cuts including permanently installed diamond tool with patented Air Stream system. Also available with optional fully automatic control with six NC servo-axes.

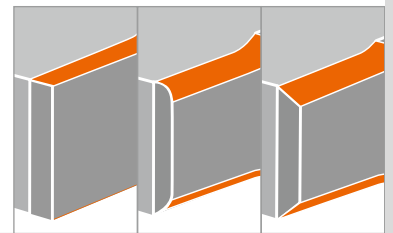

Corner rounding unit

Unit for copying vertical, end edges, various edge profiles possible – including postformed profiles. Integrated chip removal. With diamond tipped tools for long tool service life.

Working height 60 mm.

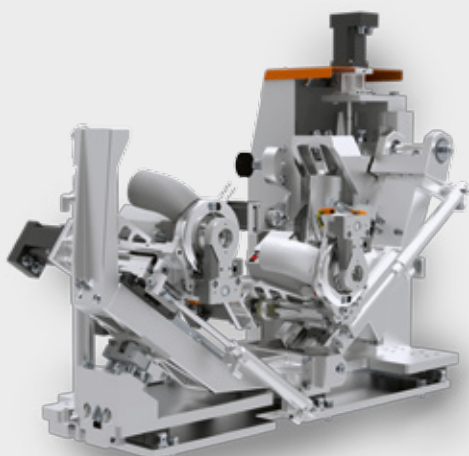
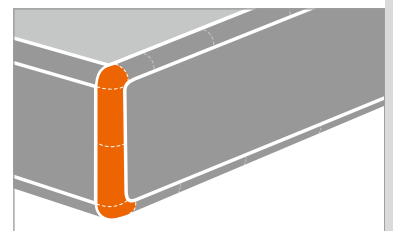

Shaping cutter unit

Unit adjustment on linear guides. With standard blast nozzles in front of sensing rollers to blow away chips in front of sensing areas. Including shelf program for optimum processing of shelves with rounded edges.

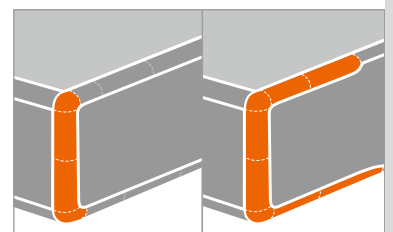



Scraper unit

For perfect smoothing of radiuses and chamfers on plastic edging.

With 4 NC servo-axes for exact adjustment of tool depth when using high gloss panels with protective foil.

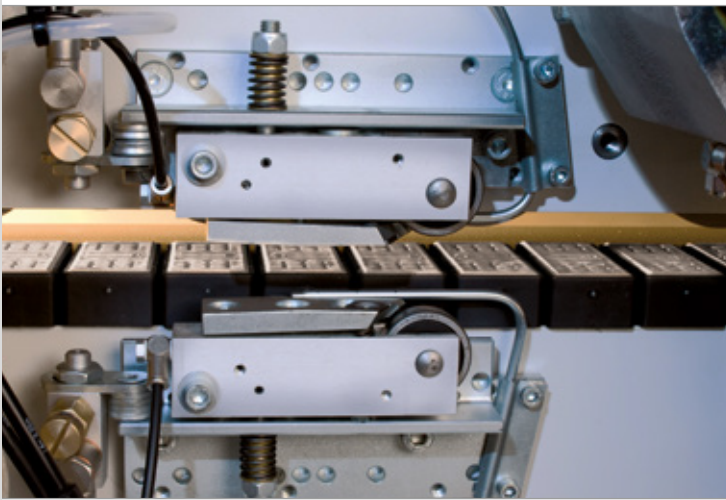
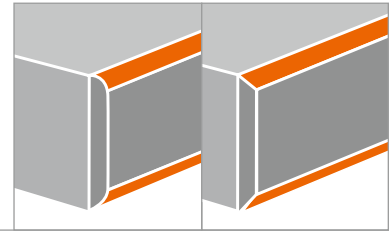

Flat scrapers (application controlled)

Clean post-processing of surfaces. Application controlled with 2 HW cutting edges, for use on 4 sides. Completely eliminates all manual finishing.

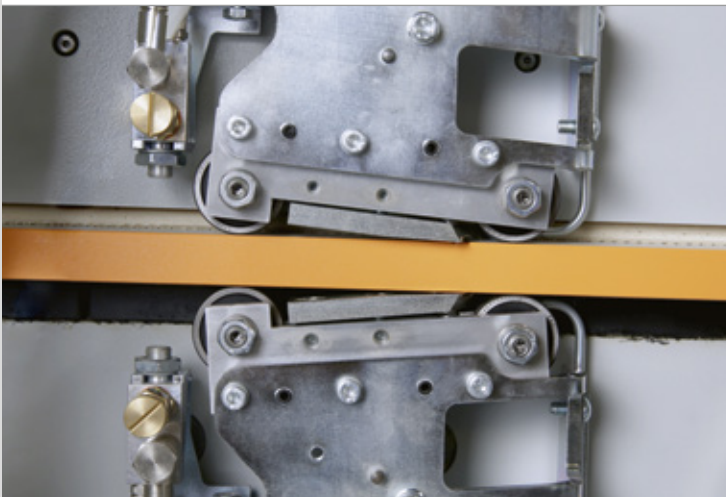
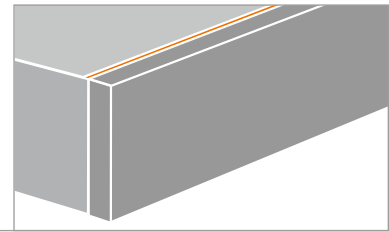

Flat scrapers (pre- and post-sensing)

Clean surface finishing with pre- and post-sensing for high feed rates. 2 HW cutting edges, for use on 4 sides. Completely eliminates all manual finishing. Both units can be lifted automatically for special applications.

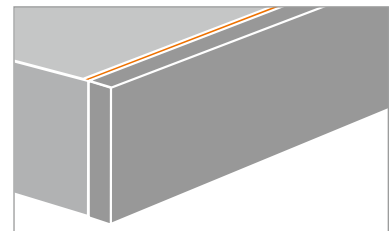

Powerful performance,
high degree of automation.

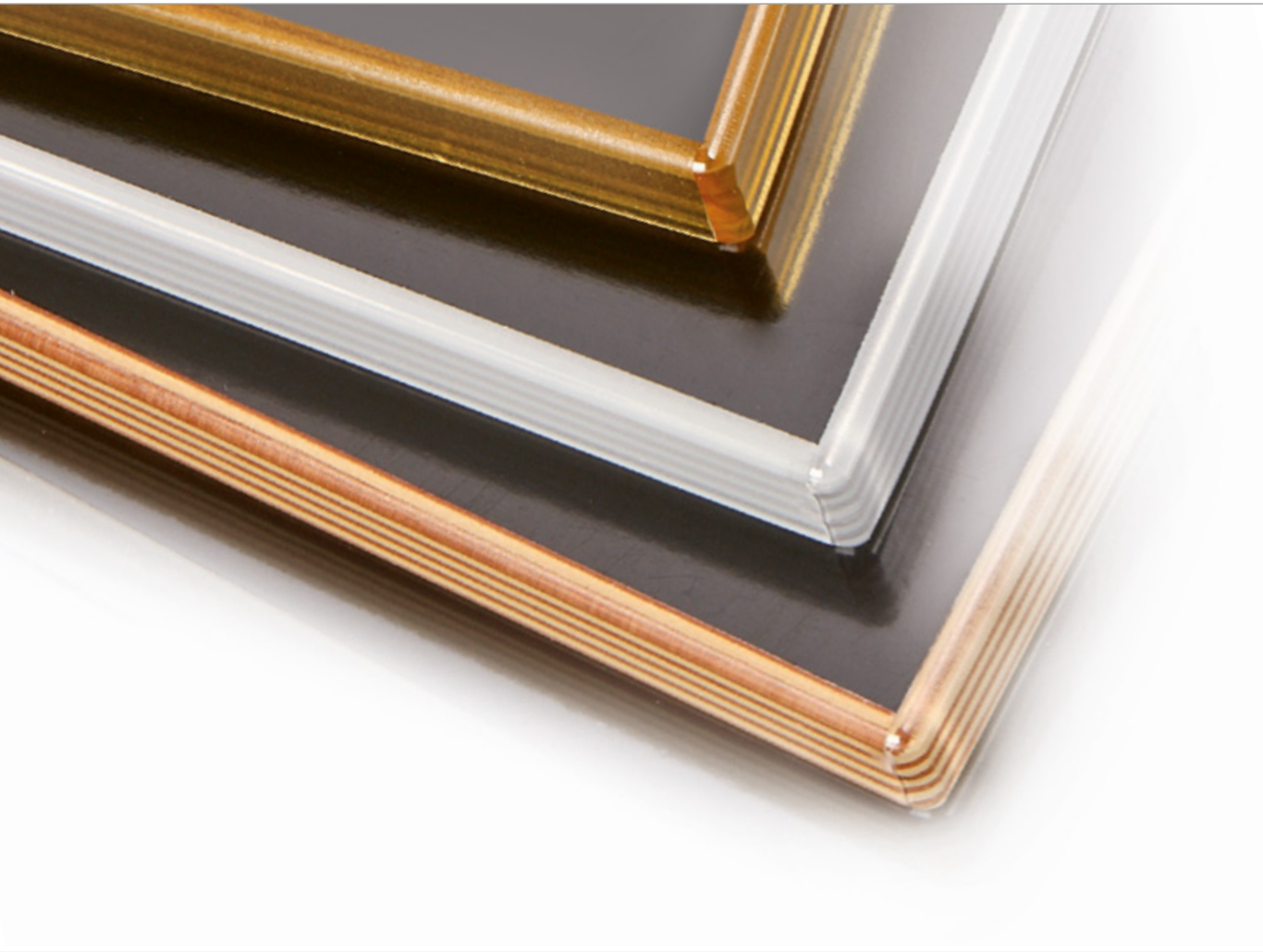

Buffing unit

Polishing for maximum gloss; for complete finishing.
Standard setup.

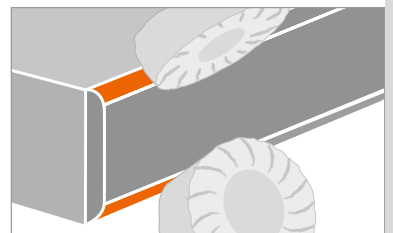

Spraying devices

Spraying units for parting agents and cleaning agents for feed and discharge area. Anti-static, coolant and lubricant – electronically controlled by special nozzles – for a perfect edge finishing. The various fluid reservoirs are all integrated cleanly into the machine frame.

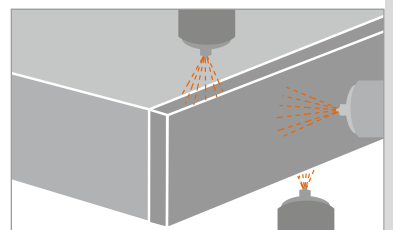

Perfectly equipped down to the last detail



1



2



3



4

■ Air cushion table

For easy and careful handling – even with bulky work pieces (optional) (Fig 1).

■ Glu Jet catch reservoir

For clean and convenient flushing (Fig 2).

■ Nesting package

For concealed hinge holes or trapezoidal work (optional) (Fig 3).

■ Long, motor-driven run-in linear guide

For optimum feed of long workpieces. Joint thickness can be adjusted automatically at the touch of a button on the motor-driven run-in linear guide (optional) (Fig 4).

■ Transport chain lubrication

Intelligent automatic transport chain lubrication. Sensor-controlled unit, for metering lubrication to match load (optional).



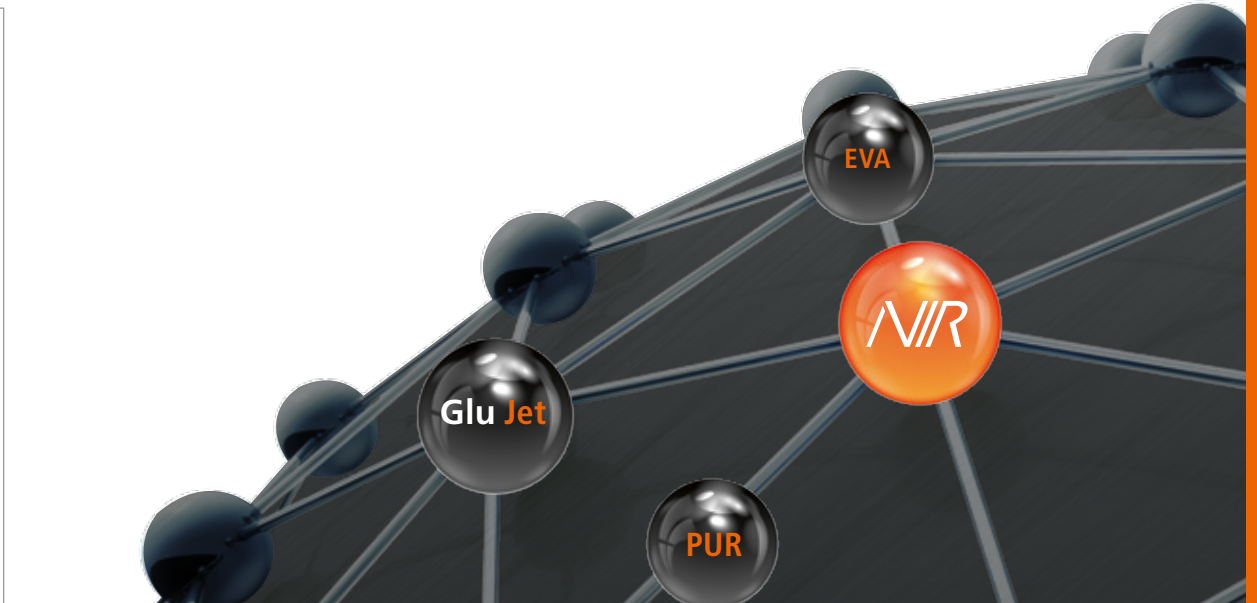

Adaptive package

The optimized, automatic control for the extensive pressure adjustments with plausibility checks allows HOLZ-HER to realize automatic glue quantity control matched to the specific requirements. Moreover, an adaptive trimming blade automatically adapts the pressure of the trimming blade to the edge thickness.

Also included is an adaptive pressure unit for optimum adjustment of the pressures of the individual pressure rollers to the specific application for perfect results every time. This reduces adjustment errors and reject quotas to a minimum (optional).

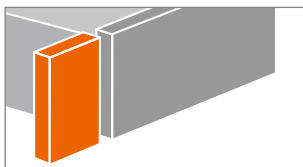

Adaptive trimming blade

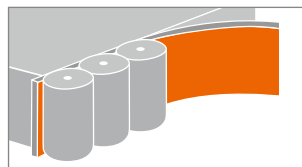

Adaptive pressure unit

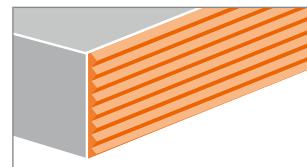

Automatic glue quantity control



> The adaptive package reduces adjustment errors and reject quotas to a minimum. <

Equipment for **LUMINA**

Machine	LUMINA 1375	LUMINA 1380
Control	18.5" Touch screen	18.5" Touch screen
Bridge	Motor-driven roller bridge	Motor-driven roller bridge
Edge feeder	LTRONIC / SYNCHRO	LTRONIC / SYNCHRO
Jointing	60 mm	60 mm
Exchange unit 1	LTRONIC with NIR	LTRONIC with NIR
	LTRONIC with NIR ^{plus}	LTRONIC with NIR ^{plus}
Exchange unit 2	Glu Jet automatic	Glu Jet automatic
Pressure unit	3 motor-driven rollers	3 motor-driven rollers
End trimming	Two-motor	Two-motor
Cutting	Multi-function, pneum. MOT 4 / MOT 6	Multi-function MOT 6
Corner copying	Single motor, 60 mm	Two-motor, 60 mm, MOT 4
Radius scraper	Pneumatic	MOT 4, incl. high gloss
	MOT 4	
Flat scraper	Flat scraper, application controlled	Flat scraper, application controlled
	pre and post tracing	
Buffing	Buffing unit	Buffing unit
Spraying device		

- Standard
- Optional
- Free space



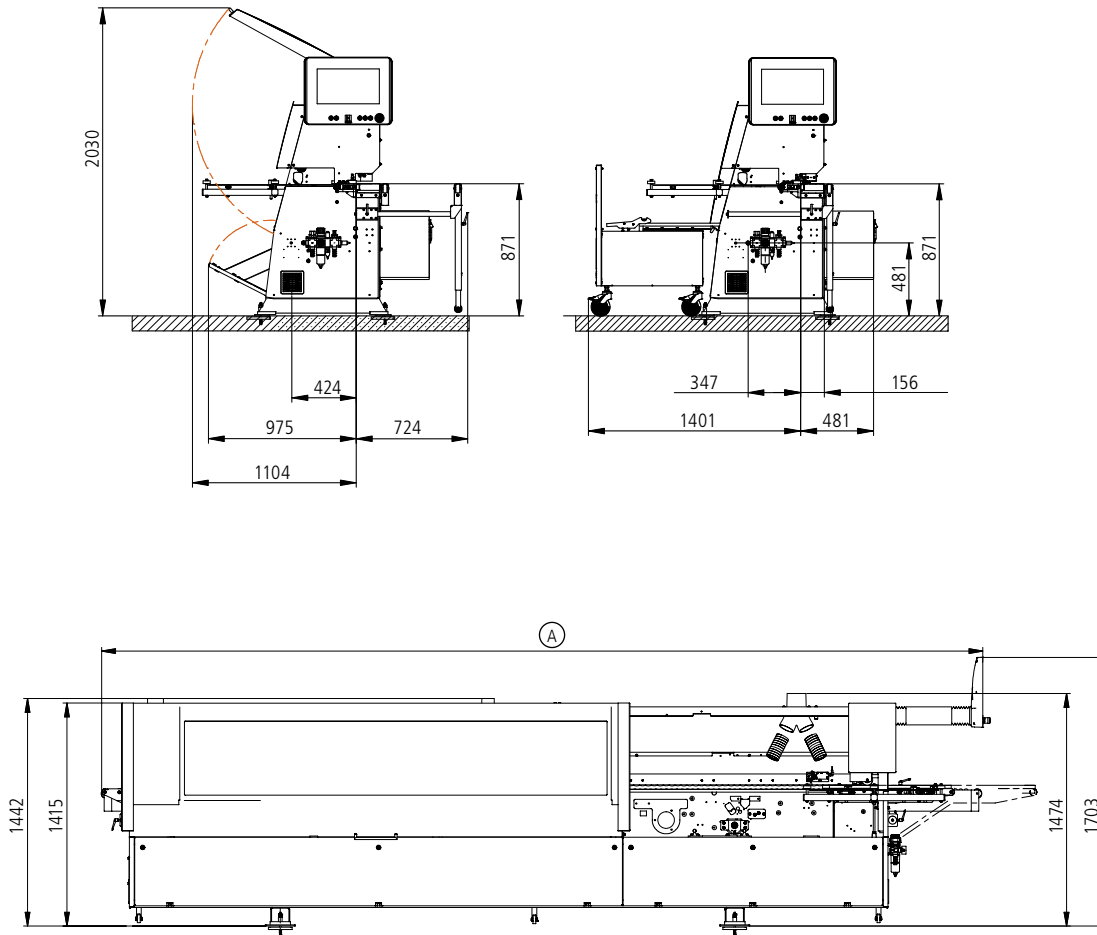

	LUMINA 1375 with Glu Jet	LUMINA 1380 with Glu Jet	LUMINA 1380 mit LTRONIC
Technical Data			
Overall length (A)	5185 mm	5587 mm	
Overall length with run-in linear guide	5537 mm	5936 mm	
Weight	2030 kg	2200 kg	
Feed Rate			
Feed speed	10–18 m/min	10–18 m/min	10–18 m/min
Working Dimensions			
Minimum workpiece length	160 mm	160 mm	160 mm
Minimum workpiece width	60 mm	60 mm	60 mm
Workpiece thickness	8–60 mm	8–60 mm	8–23 mm (45 mm**)
Edge width	0,4–8 mm (12 mm*)	0,4–8 mm (15 mm*)	0,4–3 mm

*with tool change

**with NIR^{plus}

Intelligent return system for greater efficiency

The intelligent HOLZ-HER return system is the perfect supplement to the LUMINA series. This high performance module is distinguished by its high flexibility in use and amortizes itself quickly for all lot sizes.

- A 90 /180 degree turning device is included as a standard feature.
- The return system transports the parts securely, gently and reliably back to the entry area on the LUMINA machine where they are stacked – also in nesting form.
- Feed rates from 0 to 18 m/min., automatic adaptation to LUMINA feed system.

Time losses and jams resulting from manual removal of the work are a thing of the past; economical one-man operation of the LUMINA machine becomes the rule.

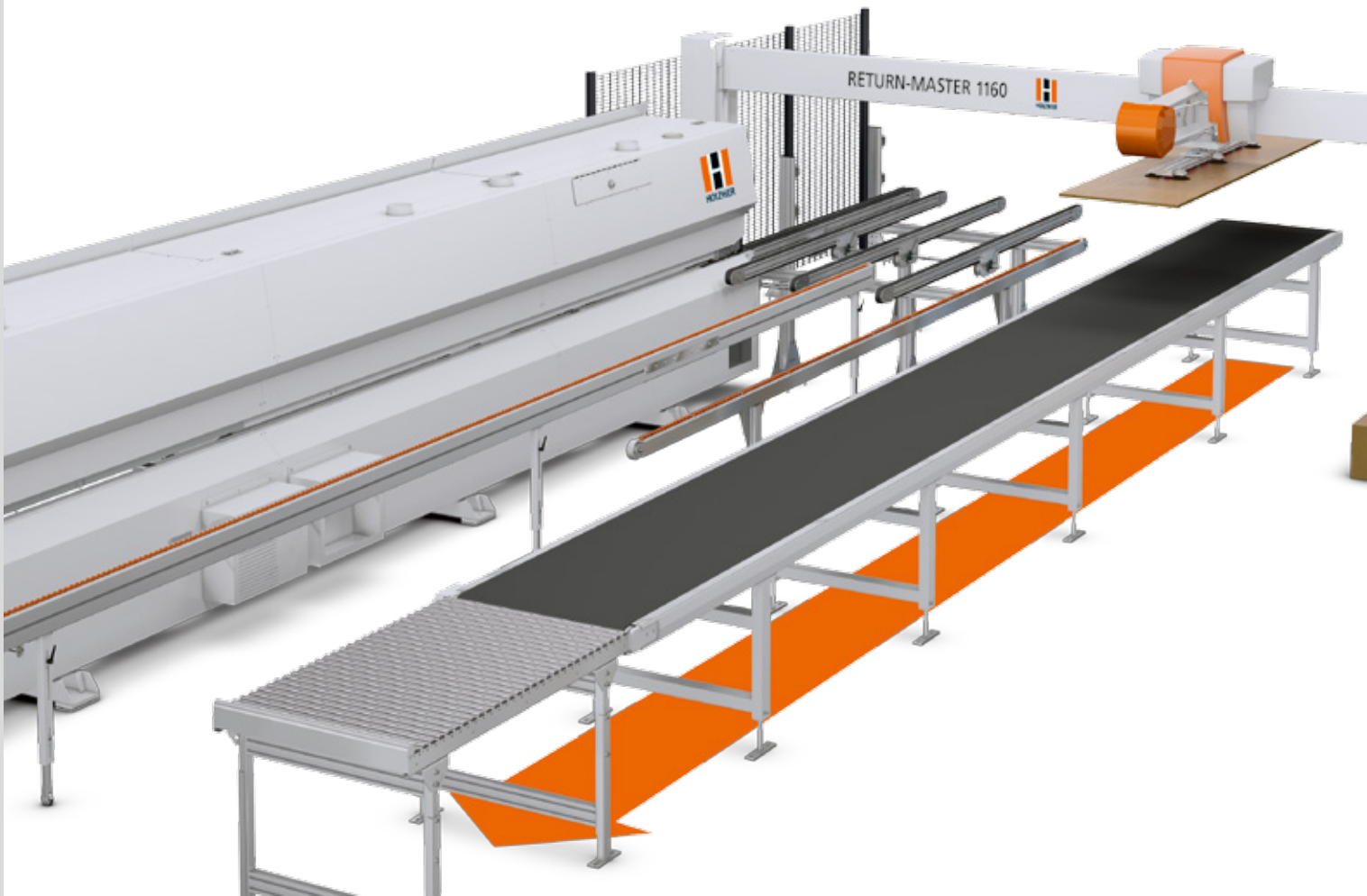

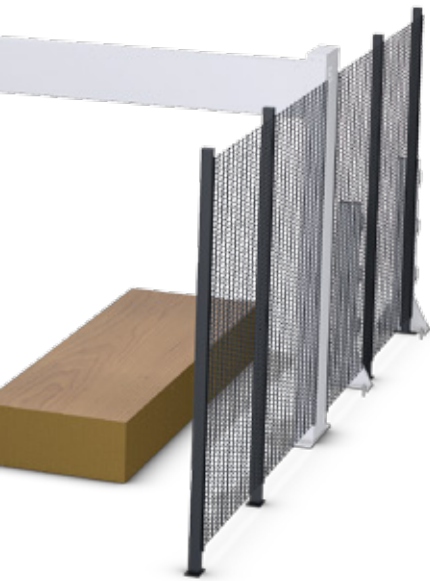
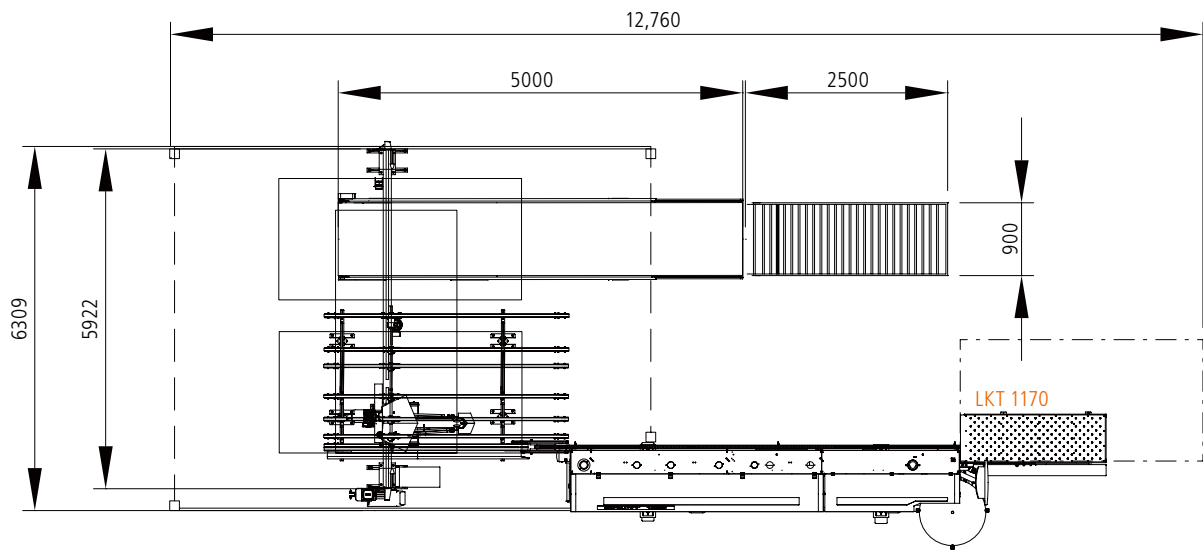

Air cushion table for improved handling

Feed using the optional air cushion table is particularly simple and gentle on material. The air cushion ensures simple, gentle handling of the work. Long parts can be positioned precisely and guided into the LUMINA machine.

Product brochures and many
videos are available at
www.holzher.com



The technical data specified is intended for reference only. HOLZ-HER woodworking machines are subject to constant development and are therefore subject to modification without prior notice. The illustrations are therefore not binding. Some of the machines shown also contain special equipment not included as a standard feature. For clarity, some of the machines are shown without protective hood.

Picture credits: © istock: lisegagne | © Fotolia: Alexander Rochau | © Shutterstock: bioraven | © Fotolia.com: Westend61 – »Deutschland, Bayern, München, Männer und Frauen diskutieren im Büro« | © Fotolia.com: Westend61– »Geschäftsleute in Bürogemeinschaft« | © Fotolia.com: psdesign1 »Network« | © Fotolia.com: natashapetrova »set of colored spheres on a white background«

UK – HOLZ-HER 3608 45 – Printed in Germany/Imprimé en Allemagne
Printed on: 17.05.2017 – First edition: 17.05.2017

Your authorized HOLZ-HER dealer

HOLZ-HER GmbH
Plochinger Straße 65
72622 Nürtingen
Germany
T +49 (0) 70 22 702-0
kontakt@holzher.com
www.holzher.com

HOLZHER

A member of the WEINIG Group