

Mixing Conditioner, Type MK



For Conditioning Feed Mixtures or Individual Components

with the addition of steam, water, and liquids



The optimum system for effective and economic thermal treatment of compound feed with firmly defined ratio of retention time and throughput. The MK is appropriate for the treatment of mash feed or as conditioner prior to the pelleting press.

Depending on the size, the conditioner is driven via a slip-on gear or V-belt drive.

Advantages of the KAHL conditioner

The KAHL conditioner fulfills all prerequisites for optimum conditioning and is characterized by:

- Large volume
- Case in stainless steel design
- Adjustable paddles to influence the residence time, the filling degree and the mixing effect
- Surface temperature sensor for measuring the product temperature
- Large inspection doors facilitating any clean-out

Mixing Conditioner, Type MK

Requirements on conditioning:

- Product and process specific conditioning is the decisive pre-requisite for achieving the highest feed quality.
- Optimum conditioning is required for the effective performance of the downstream pelleting presses or annular gap expanders.

- A good filling degree of the conditioner and an appropriate retention time result in a uniform and sufficient absorption of steam and added liquids.
- The uniform distribution of the added substances will be facilitated by a thorough mixture of the solid and dry matters.

- Optimum product treatment requires precise monitoring of the conditioning parameters, such as temperature, moisture, and homogeneity of the mixture.

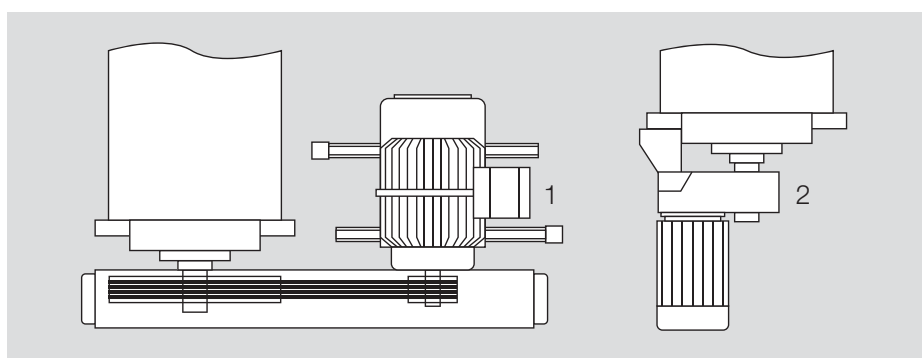

Available drives

- 1 V-belt drive
- 2 Offset gear drive

Dimensional standard

Type	ø mm	Length mm		Height mm	Contents litre ¹ ca. 60 % abt. 60 % filling degree	Drive ² kW	Throughput t/h ³ 30 sec. retention time	Throughput t/h ³ 60 sec. retention time
		L	M					
MK 200	200	2500	1200	350	20	3-4	0.3	0.6
MK 315	315	3160	1500	530	66	4-9.2	4	2
MK 400	400	3250	2000	670	143	7.5-11	9	4.5
MK 550	550	3400	2150	840	250	11-18.5	15	7.5
MK 630	630	4050	3000	910	470	15-22	28	14
MK 800	770	3400	2600	1050	600	22-30	36	18

(Special dimensions are available upon request)

¹ Contents \triangleq useful contents, ² Drive power depends on the level of liquid addition,

³ Throughput calculated for a bulk density of 600 kg/m³



AMANDUS KAHL GmbH & Co. KG

Dieselstrasse 5-9
D-21465 Reinbek / Hamburg
Phone: +49 (0)40 727 71 - 0
Fax: +49 (0)40 727 71 - 100
info@amandus-kahl-group.de
www.akahl.de